

06 - 2001 S. AG.

2 - Hood

CODE	DESCRIPTION
150819	CABLE HOLDER PG16 WITH HOLE
160772	PLUG FOR DOOR (BR-BC-FC)
160804	GASKET D.6
160838	SLIDING WASHER TIE ROD FC
160840	WASHER
160905	SLIDING PLATE F. TIE ROD
180506	DOOR CATCH BR-BC-FC
190619	DOOR CATCH B-F-R
200923	DOOR GASKET
260223	M5X12 MSH/HD SCREW SPECIAL S/S
260238	M4 X 10 MUSH/HD SCREW
260247	SCREW TCB 5X16
260250	SCREW TB 5X20
260414	SELF-LOCKING NUT M5
260503	STAINL.STEEL FLAT WASHER D5 UN
260512	ST/ST GROWER WASHER D6
260542	WASHER D.5
320395	TOP PANEL FC
321807	DOOR HINGE FC MACHINES
322417	RIGHT GUIDE FC
322418	LEFT GUIDE FC
322940	DOOR FC53-FC53A
322941	DOOR FC54-543-544-HR
330233	FC DOOR TIE ROD
331764	FIXING PLATE FOR B-F DOOR GASK
341218	HINGE PIN B-F-G
341481	HOOD FC53/53A
341482	HOOD FC54-543-544-HR
342010	PIN FOR TIE ROD DOOR FC
351349	LATERAL PANEL FC53
351350	LATERAL PANEL FC53
351351	LEFT PANEL FC54-544-543-HR
351352	RIGHT PANEL FC54-543-544-HR
351353	FRONT PANEL FC
351526	LOWER FRONT PANEL
390150	LOWER BACK PANEL FC
390158	BACK PANEL FC53A
390159	BACK PANEL FC54A
440201	RUBBER FOOT D.60X10
450821	SPRING CLIP FASTENER SNU 3634
463016	FC53 NAME
463017	FC53A NAME
463018	FC54 NAME
463019	FC54A NAME
463020	FC543 NAME
463021	FC543A NAME
463068	FC533 NAME
463069	FC533A NAME

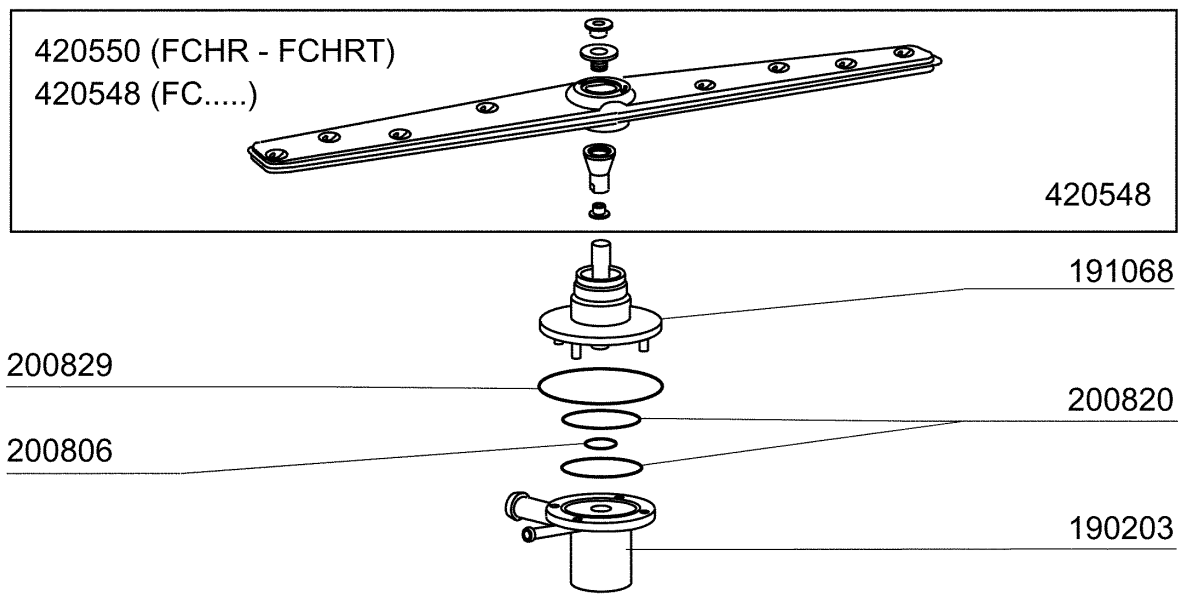
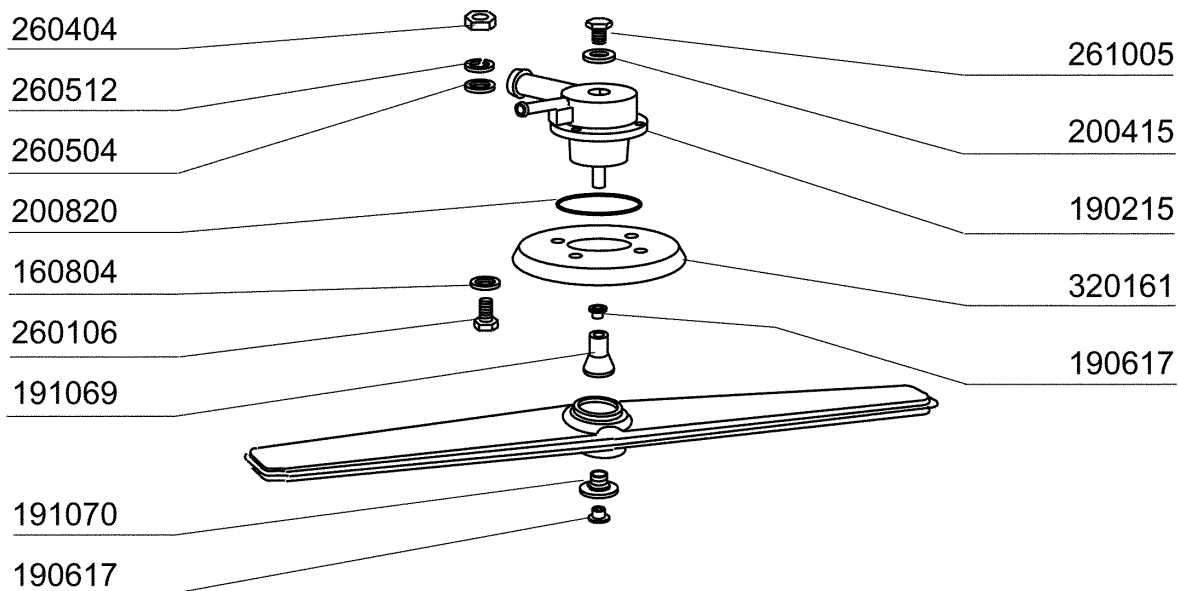

3 - Wash arm

CODE	DESCRIPTION
160804	GASKET D.6
190203	LOWER TEE WASH-RINSE F2-45-55-
190215	UPPER WASH/RINSE ARM SUPPORT F
190617	BUSH
191068	LOWER WASH ARM SUPPORT FC-MACH
191069	WASH ARM CENTER (FC - MACHINES
191070	LOCK NUT FOR WASH ARM CENTER (
200415	AIR TRAP GASKET -F2 18,5X10X3
200806	O-RING 2,62X13,10X18,34
200820	O-RING151 46,99X5,33X57,6
200829	O-RING 81,92X92,58X5,33
260106	SCREW TE 6X25
260404	STAINLESS STEEL NUTS D6 UNI 55
260504	ST/ST FLAT WASHER D6
260512	ST/ST GROWER WASHER D6
261005	SCREW F. TEE UP.WASH F2-B41
320161	UPPER WASH ARM PROTECTION
420548	FC WASH ARM (ST/ST)
420550	WASH ARM FCHR - FCHRT

sino alla matricola
jusqu'à la matr.
up to serial no.
bis Seriennr.
hasta la matr.

11091/10/98

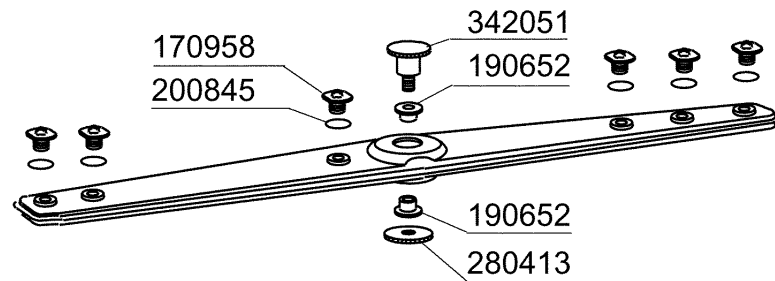

dalla matricola
à partir de la matr.
from serial no.
ab Seriennr.
despues la matr.

11092/10/98

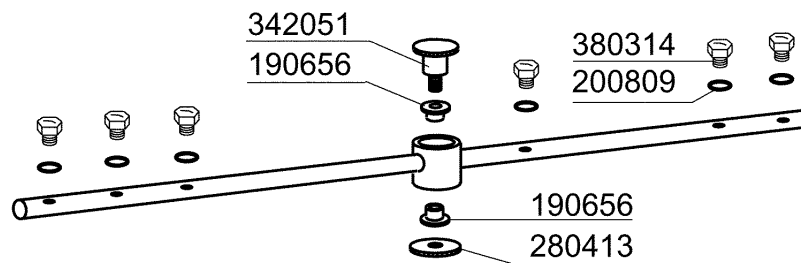

dalla matricola
à partir de la matr.
from serial no.
ab Seriennr.
despues la matr.

3551/04/00

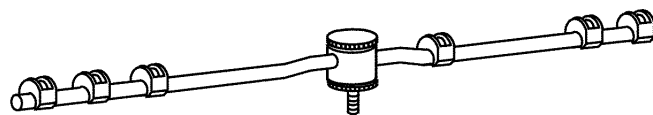
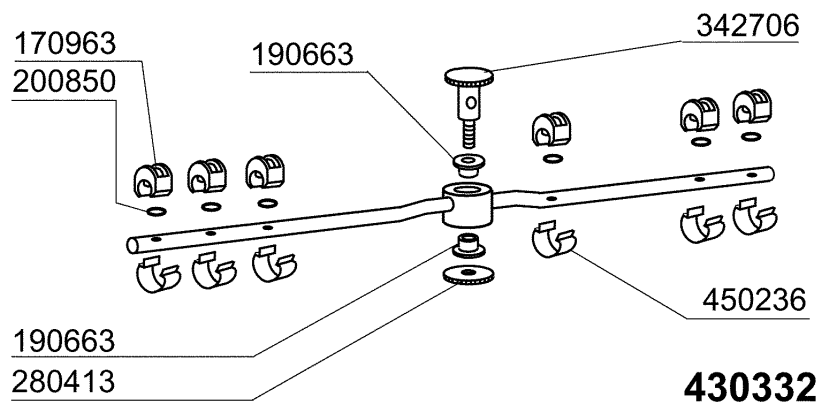

430332

4 - Rinse arm

CODE	DESCRIPTION
170958	RINSE JET FOR FC53-543
170963	RINSE JET X FC
190652	RINSE ARM BUSH FC
190656	BUSH RINSE ARM FC
190663	BUSH
200809	OR GASKET 1,78X8,73X12,29
200845	O RING 109 2,62X9,13X14,37
200850	O-RING
280413	RETAIN.LOCK NUT FOR FC RINSE A
342051	RINSE ARM SUPPORT FC
342706	SHAFT
380314	RINSE JETS 801/HR
430332	RINSE ARM FC 01/00
450236	SPRING FOR WASHER 170963

- 450114 (22 - 32)
- ◆ 450106 (32 - 44)
- ⊙ 450135 (44 - 56)
- ◆ 450109 (50 - 65)

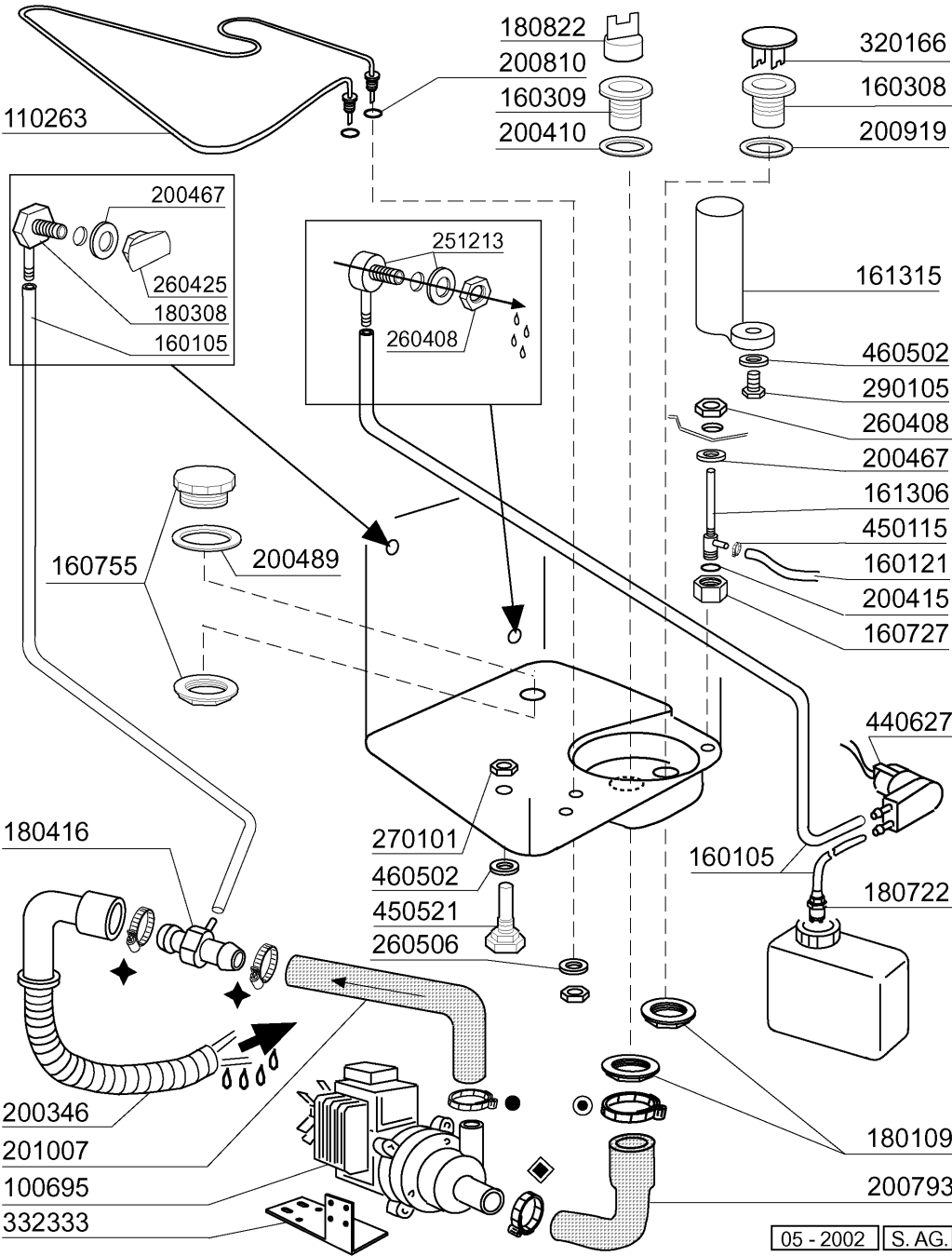

05 - 2002 | S. AG.

5 - Tank HR

CODE	DESCRIPTION
100695	DRAIN PUMP 220V-50
110263	TANK HEATER 2000W 230V
160105	INJECT.INLET HOSE D.6X4
160121	HOSE EPDM D. 5 X 9
160308	PUMP INLET HOSE FC
160309	DRAIN OUTLET FC DUMPER
160727	PLUG 1/2 NTP CAP
160755	PLUG FOR MACHINES WITHOUT SOFT
161306	HOSE FOR AIR CHAMBER F45-80
161315	AIR TRAP HRT-HT
180109	LOCK NUT 1 1/2"
180308	INJECTOR
180416	TEE FOR DRAIN PUMP "HR"
180722	DETERGENT DISPENSER STREINER
180822	DRAIN FILTER FOR FC"HR"
200346	DRAIN HOSE GLASSWASHER
200410	DRAIN OUTL.WASH.1 1/2"65X47X2
200415	AIR TRAP GASKET -F2 18,5X10X3
200467	DUTRAL GASKET F. AIR TRAP
200489	GASKET 81X68X3
200793	DRAIN PUMP INLET HOSE FC
200810	O-RING 2,62X9,92X15,6 F.GLASSW
200919	GASKET FOR SUCTION BASIN FC
201007	DRAIN PUMP HOSE EXTENSION
251213	INJECTIOR S/S FOR DETERGENT IN
260408	S/S NUTS D.12
260425	LEAKING NUT FOR DRAIN PUMP HR
260506	STAINL.STEEL FLAT WASHER D10
270101	HEXAGON LOCK NUT 1/2"
290105	BRASS-TE-PLUG 1/2"
320166	VORTEX BREAKER FOR FC MACHINES
332006	TANK FILTER FC-HR
332333	BRACKET FOR DRAIN PUMP
440627	DETERGENT DISPENSER
450106	CLAMP FE ZN 32-44 H=12,2
450109	CLAMP 50-65
450114	CLAMP FE ZN.22-32 H=12,2
450115	ELASTIC CLAMP D.8,3/7,8
450135	CLAMP FE ZN. 44-56 H=12,2
450521	TANK THERMOSTAT SHIELD
460502	GASKET 30X21X2

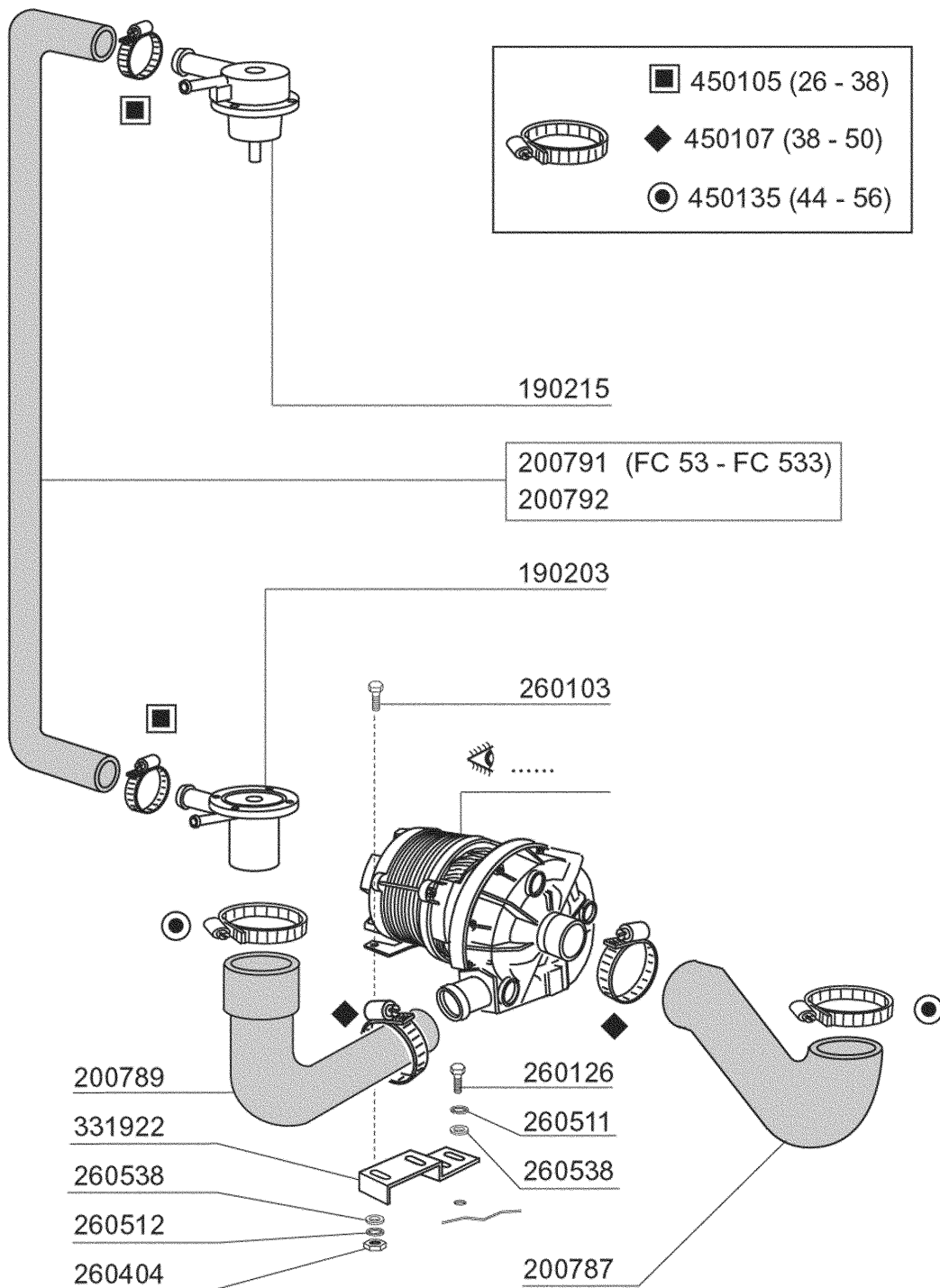

6 - Wash

CODE	DESCRIPTION
190203	LOWER TEE WASH-RINSE F2-45-55-
190215	UPPER WASH/RINSE ARM SUPPORT F
200787	INLET HOSE FC53-FC544-FCHR
200789	OUTLET HOSE FC
200791	UPPER/LOWER WASH HOSE FC53
200792	HOSE FOR UPPER/LOWER WASH FC54
260103	SCREW TE 6X12
260126	SCREW TE 5X12
260404	STAINLESS STEEL NUTS D6 UNI 55
260511	GROWER WASHER D.5
260512	ST/ST GROWER WASHER D6
260538	WASHER 18X6X1,5 ST/ST
331922	BRACKET F. PUMP "F"
450105	CLAMP FE ZN. 26-38 H=12,2
450107	CLAMP FE ZN 38-50 H=12,2
450135	CLAMP FE ZN. 44-56 H=12,2

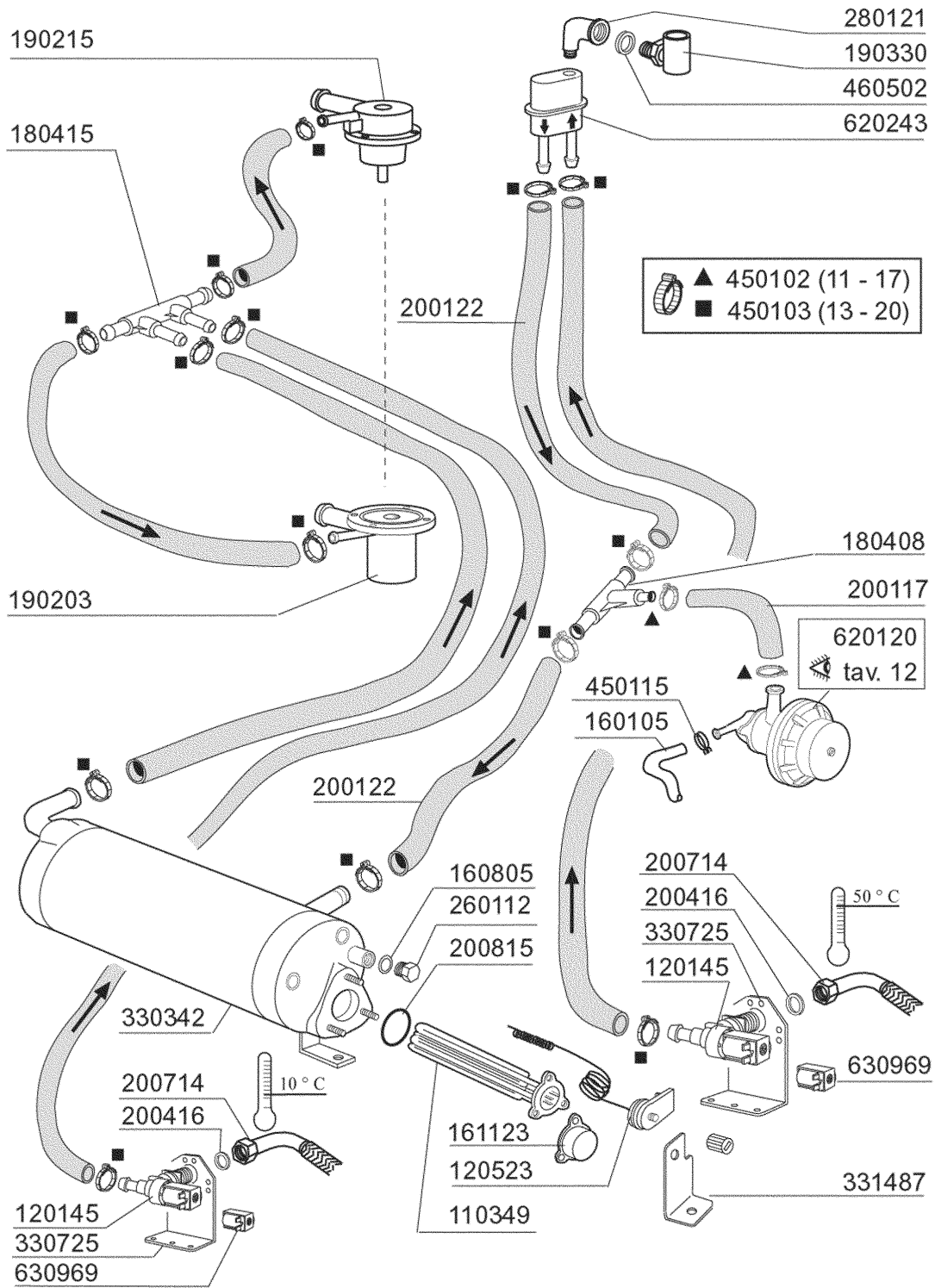

7 - Rinse E-HR-HRT

CODE	DESCRIPTION
110349	HEAT.ELEMENT 6000W 230/400V
120145	SOLENOID VALVE 12 LT 1 WAY
120523	SAFETY THERMOSTAT 110Ø
160105	INJECT.INLET HOSE D.6X4
160805	GASKET D.8
161123	HEAT.ELEMENT COVER H42 SNL
180408	TEE-NIPPLE F.INJECT.W/CENTR.RE
180415	TEE NIPPLE DOUBLE "T"
190203	LOWER TEE WASH-RINSE F2-45-55-
190215	UPPER WASH/RINSE ARM SUPPORT F
190330	TEE FOR VAACUM BREAKER
200117	RUBBER HOSE 7X16
200122	HOSE 11X19
200416	GASKET D. 3/4"
200714	GLASSWASHER INLET HOSE
200815	O-RING F. HEAT.ELEM.
260112	STAINLESS STEEL TE-SCREW 8X16
280121	ELL FOR VAACUM BREAKER
330342	BOILER C95-C155-C165
330725	STANDARD BRACKET F.SOLEN.VALV
331487	BRACKET FOR 1 THERMOSTAT
450102	CLAMP FE ZN 11-17 H=9
450103	CLAMP FE ZN. 13-20 H=9
450115	ELASTIC CLAMP D.8,3/7,8
460502	GASKET 30X21X2
620120	RINSE AID INJECTOR
620243	VACUUM BREAKER (WITHOUT KIT)
630969	COIL S4216 220/50HZ

631652 (50 Hz)

630413

630116

630222

630501

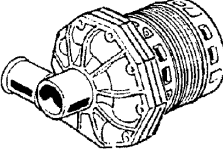

100399
220/240 V
50 Hz HP 0,6
Kw 0,45



631206
(10 μ F)

631683 \varnothing 93 (50 Hz)
631684 \varnothing 80 (60 Hz)

630419

630129

630240

630501

dalla matricola
a partir de la matr.
from serial no.
ab Seriennr.
despues la matr.
4755/04/01

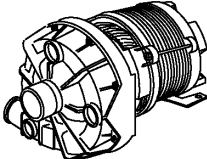

100740 220/240 V 50 Hz HP 0,6 - 4247
100744 220/200 V 60 Hz HP 0,6 - 4247
Kw 0,45



631206
(10 μ F)

8 - Pump

CODE	DESCRIPTION
100399	PUMP HP0,6 220-50HZ (100740)
100740	PUMP 0,6HP 220/240V 4247
100744	PUMP HP 0,6 200-220-60HZ
630116	-NO MORE AVAILABLE
630129	VOLUTE PUMP 0,5HP 2247
630222	COVER PUMP IB HP 0,4
630240	PUMP FLANGE 0,6HP-4247 FIR
630413	-NO MORE AVAILABLE
630419	PUMP GASKET 2247 0,5HP
630501	SEAL FOR PUMP HP 2-3-3,2
631206	CONDENSER 10MF. 450V 85C
631652	-NO MORE AVAILABLE
631683	PUMP IMPELLER 50HZ FIR 4247
631684	IMPELLER FOR PUMP 60 HZ



9 - Rinse aid injector

CODE	DESCRIPTION
160714	PLUG FOR RINSE AID INJECTOR MO
170701	LOCK NUT 1/2" F.INJECTOR
180306	NIPPLE F.RINSE AID INJECTOR
190107	COVER FOR RINSE AID DISPENSER
190108	VOLUTE FOR RINSE AID DISPENSER
190803	GASKET SUPPORT RING F.INJECT
191018	FILTER SUPPORT RINSE AID INJEC
200444	SUCTION VALVE RINSE INJECTOR
200816	O-RING 2,5X59,2X64,2 RINSE INJ
200825	O-RING 3X5X11 RINSE INJECTOR
200861	O-RING 14X18X2
260142	SCREW TE 4X16
260213	SCREW TCP 5X25
260402	STAINLESS STEEL NUT D4 UNI 55
260404	STAINLESS STEEL NUTS D6 UNI 55
260512	ST/ST GROWER WASHER D6
330543	FILTER RINSE AID INJECTOR D.17
340483	PISTON FOR RINSE AID DISPENSER
381105	DIAPHRAGME DISC
440405	GASKET FOR RINSE AID INJ.
450214	SPRING RINSE AID INJECTOR
620120	RINSE AID INJECTOR
630614	DIAPHRAGM RINSE INJECTOR

10 - Control box with electronic printed circuit

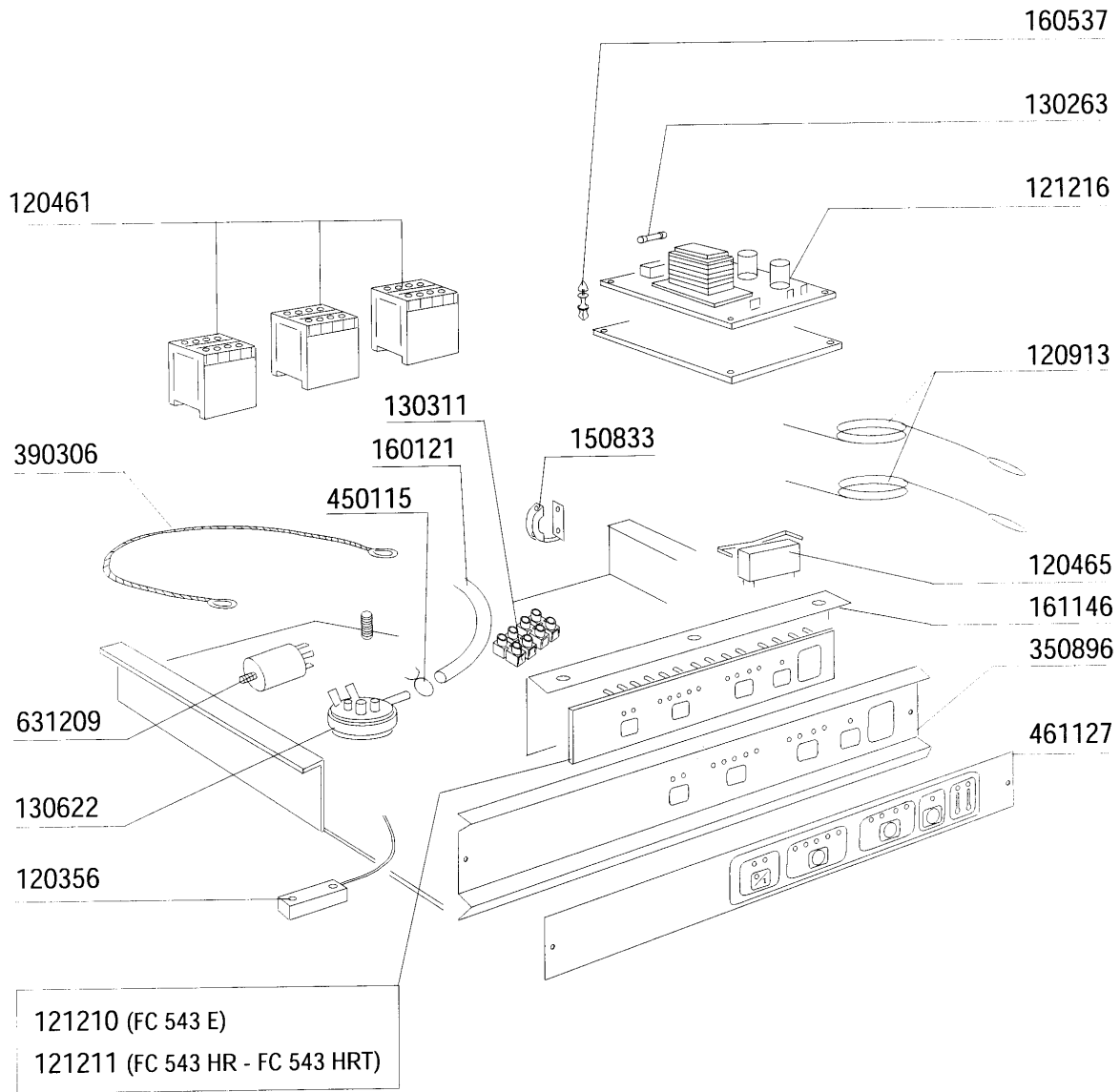

10 - Control box with electronic printed circuit

CODE	DESCRIPTION
120356	DOOR MAGN.SWITCH
120461	CONTACTOR ABB B6-30-01 220V
120465	RELAIS 16A 12V
120913	PROBE FOR FC+C PCB
121210	PCB FOR FC
121211	PCB FOR FCHR
121216	TRANSFORMER FOR PCB FC
130263	FUSE 5X20 T400MA
130311	TERMINAL BLOCK
130622	PRESSURE SWITCH 48-28 FCHR-HRT
150833	CABLE HOLDER BC/BR
160121	HOSE EPDM D. 5 X 9
160537	ELECTRONIC CARD SPACER
161146	PROTECTION FOR ELECT.TIMER
350896	CONTROL PANEL SUPPORT FOR FC54
390306	CABLE
450115	ELASTIC CLAMP D.8,3/7,8
461127	PLATE FC543E-FCHR
631209	ANTI-NOISE FILTER

620242

200467

251213

260408

200607

180719

10 - 2000 S. AG.

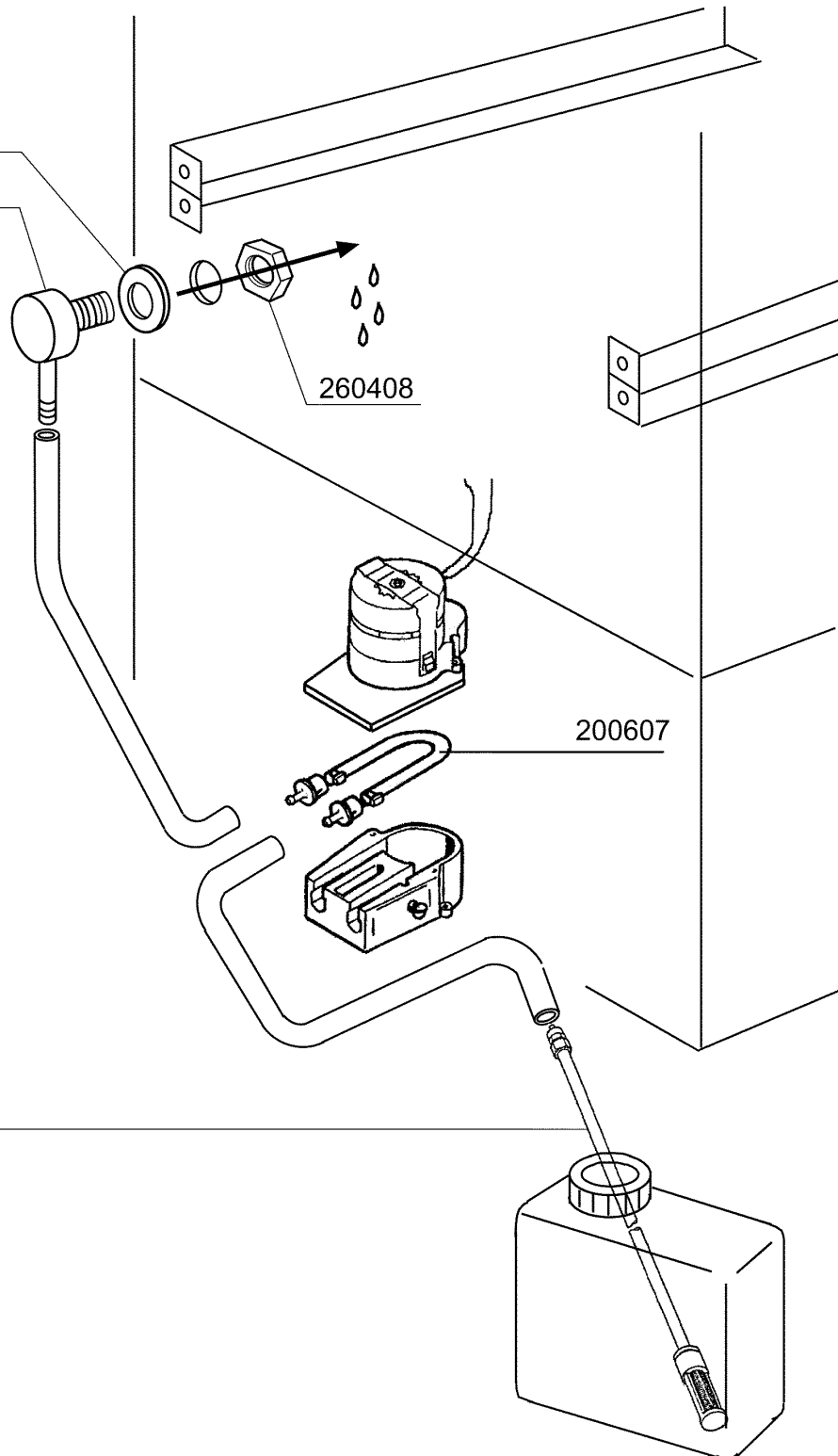

11 - Detergent dispenser

CODE	DESCRIPTION
180719	DETERGENT DISPENSER SUCTION HO
200467	DUTRAL GASKET F. AIR TRAP
200607	DETERGENT DISPENSER HOSE
251213	INJECTIOR S/S FOR DETERGENT IN
260408	S/S NUTS D.12
620242	DETERGENT INJECTOR (KIT)